

# **VISION** **VERSA-RACK**

**SLOTTED STAINLESS STEEL**

**Rack Assembly Instruction Manual**



Congratulations on the purchase of your Vision Versa-Rack.

Please follow our instructions in the exact order shown as this will ensure a smooth assembly. Don't worry, we have created a step-by-step instructional video and our sales support team is available should you have questions or need assistance.

## PRIOR TO ASSEMBLY

- Read all instructions thoroughly prior to starting Versa-Rack assembly.
- Deviation from the carefully thought-after process may result in confusion or the need to start over.
- Do NOT use alternative assembly methods.
- Refer to the instructional video for further assistance:  
<https://www.visionproducts.us/support/sss-reptile-versa-rack-assembly/>
- Use the detailed packing list located in the box to inventory each part to ensure nothing is missing or damaged.
- Refer to the packing list and sales order for part quantities as they may differ from what is shown in this manual.
- Extra parts may be provided and will be indicated on your packing list.
- Gather all tools prior to assembly
- If you have problems with assembly or are missing parts, please call or email our sales support teams for assistance.  
(920) 886-1220   Sales.Support@customcages.com   <https://www.visionproducts.us/contact>

## WARNING

### Assembly

One person can assemble the Versa-Rack on their own. However, two people are recommended for additional safety and ease of assembly when building larger stacked racks.

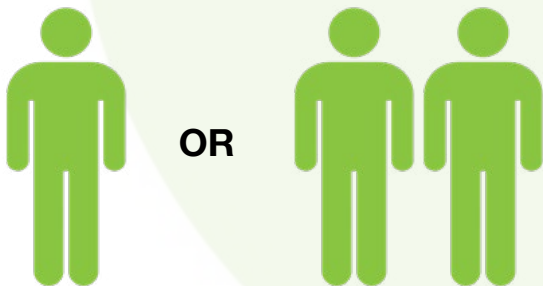

## TOOLS NEEDED

The following tools are not included with your Versa-Rack purchase.



Philips Screwdriver



Pliers



Wrench



Rubber Mallet

# TABLE OF CONTENTS

Introduction .....	2
Hardware .....	4
Rack Overview.....	5
<b>Step 1</b> Insert Poles Into First Shelf.....	6-7
<b>Step 2A</b> Riveted Guide Stops.....	8
<b>Step 2B</b> Place Spacers For Tub Height and First Stainless Steel Shelf.....	8
<b>Step 3</b> Place Spacers for Lighting Profile Height & Repeat.....	9
<b>Step 4</b> Stack Different Rack Sections Together.....	10
<b>Step 5</b> Tightening The Rack Together.....	11
<b>Step 6</b> Attaching Optional Accessories.....	12-15
<b>6A</b> Heat Cables.....	12-13
<b>6B</b> Security Clips.....	14
<b>6C</b> 10 Outlet Surge Protector and Mounting Bracket.....	15

# VISION **VERSA-RACK**

## Slotted Stainless Steel Reptile Rack Assembly Instructions

### HARDWARE

- Use the detailed packing list located in the box to inventory each part to ensure nothing is missing or damaged.
- Refer to the packing list and sales order for part quantities as they may differ from what is shown in this manual.

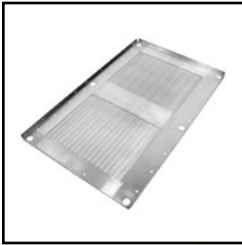

Slotted Stainless Steel Shelves

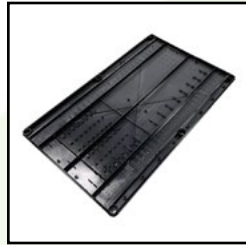

Large Rack Shelves



Vertical Poles



Female Pole Ends



Rack Shelf Spacers



Rack Tightening Bolts



Rack Tightening Washers



Caster Set



Feet Set

### OPTIONAL HARDWARE



Tubs



Riveted Guide Stops



Guide Rivets



Male Pole Connectors



Tub Security Clips



Heating Cables



10-Outlet Surge Protector



Surge Protector Mounting Bracket



Lighting & Heating Options

## RACK OVERVIEW

The Vision Slotted Stainless Steel Versa-Rack is designed to accommodate overhead lighting, heating, and ventilation for reptile or mammal breeding and husbandry in a rack. Four different variations accommodate short or tall tubs and low – or high-profile lighting, ensuring ultimate flexibility as your needs change.



**Low Profile Lighting  
Short Tubs**



**Low Profile Lighting  
Tall Tubs**



**High Profile Lighting  
Short Tubs**



**High Profile Lighting  
Tall Tubs**

This manual will go over how to assemble your Slotted Stainless Steel Versa-Rack step-by-step. While not every rack combination will be shown in this manual, each follows a similar build process that can be scaled up depending on the number of sections ordered. Please follow the steps in the exact order shown, as deviating from the carefully thought-out process may result in confusion or having to start over.



**1 Section**



**2 Sections**



**3 Sections**



**4 Sections**

# Step 1: INSERT POLES INTO FIRST SHELF

Video 2:49

The Vision Versa-Rack system is designed to stack multiple rack variations on top of each other to accommodate different lighting and heating requirements in one rack.



Decide which section will be the bottom of your rack, and check your packing list for the corresponding pole lengths.



Vertical poles will be one of four length variations.



Check the lengths of the poles against the rack type purchased on the spec sheet.

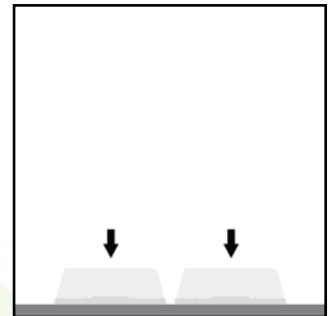

Place the two tubs you wish to use in the first section, face down on the floor.



If using heat cables in the rack, place the Rack Shelf with built-in runs facing up.



If heat is not required, place the flat side up to provide a smoother platform for removing and inserting tubs.

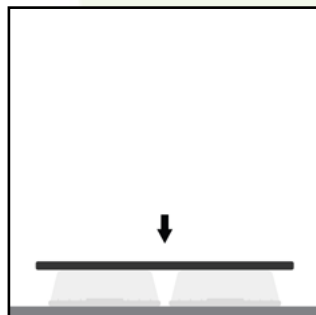

Place large Rack Shelf on top of the tubs.

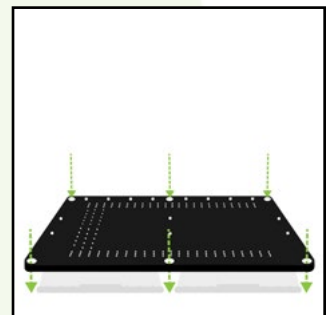

Ensure all 6 holes in the shelf are clear and not covered by the tubs underneath before proceeding.

## Step 1 Continued: INSERT POLES INTO FIRST SHELF



Attach Female Pole End to bottom of each pole. (X6)

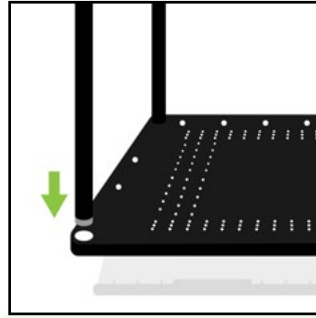

Slide each pole into each of the 6 holes in the Rack Shelf.

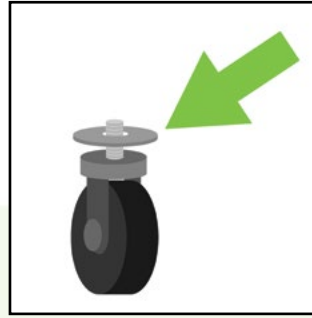

If using the 90lb-rated casters on your rack, place the washer (included with your rack) onto each caster stud before threading into the pole. (x6)

Skip to the next diagram for all other casters and feet.

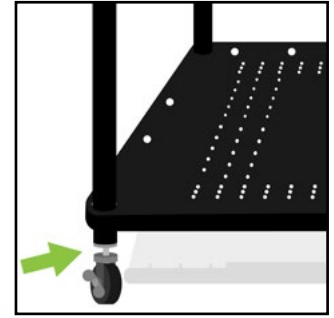

Pull up each pole slightly and screw casters or feet into the female pole end of each pole. (X6)

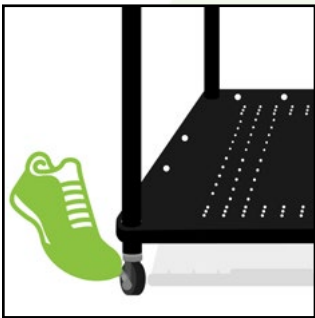

Two locking casters will be provided with each caster set. Ensure installation on an accessible part of the rack. **Once completed, remove tubs from under rack.**

## Step 2A: RIVETED GUIDE STOPS (Optional)

[Video](#) 4:50

If Riveted Guide Stops are not used, proceed to **Step 2B**.

Complete this step prior to rack assembly.

Position 6" & 14" Guide Stops to suit your needs. Standard placements shown below.



Place rivets through holes at the ends of the guide stops.

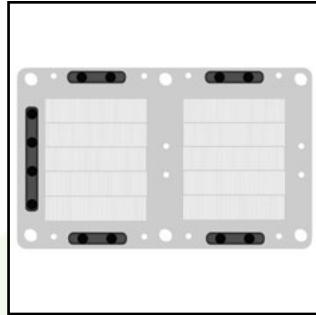

**V-70 Tubs:** Place 6" guides on the long ends of the shelf. Place a 14" guide on a short end of the Stainless Steel Shelf.

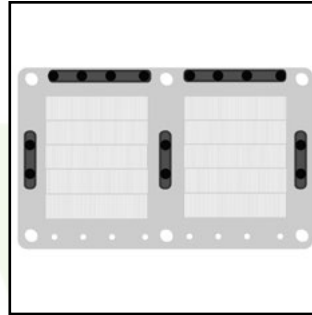

**V-15, V-18, V35s & V-35 Tubs:** Place 6" guides on the middle and short ends of the shelf. Place 14" guides on the back end of the Stainless Steel Shelf.

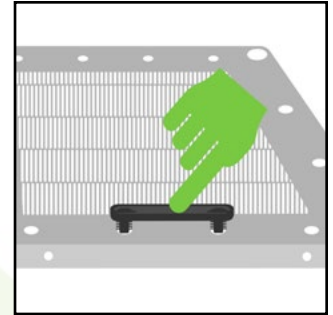

Attach guide stops to bottom of stainless steel tray through holes along the edges.

## Step 2B: PLACE SPACERS FOR TUB HEIGHT AND FIRST STAINLESS STEEL SHELF

[Video](#) 5:38

The Versa-Rack system uses two different spacer heights depending on the tub used in your rack.

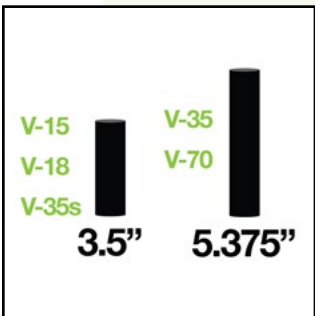

Use 3.5" Spacers for V-15, V-18 & V-35 Tubs.

Use 5.375" Spacers for V-35 and V-70 Tubs



Place Spacers on each of the 6 poles. Spacers should rest on large rack shelf.

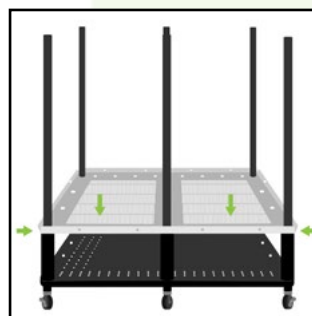

Slide a Stainless Steel Shelf onto the 6 poles and rest it on the 6 spacers.



If you have trouble sliding the shelf onto the poles a **light** tap with a rubber mallet or your hands may be used.



Do not use excessive force as this may damage the shelf.

### Step 3: PLACE SPACERS FOR LIGHTING PROFILE HEIGHT & REPEAT

[Video](#) 6:17

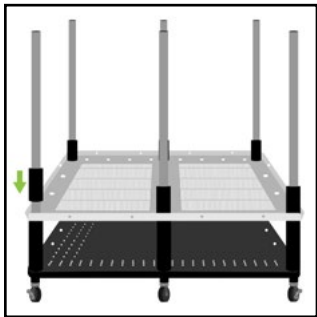

For **Low-Profile** lighting racks, slip a 3.5" spacer onto each of the 6 poles to rest on the stainless steel shelf.

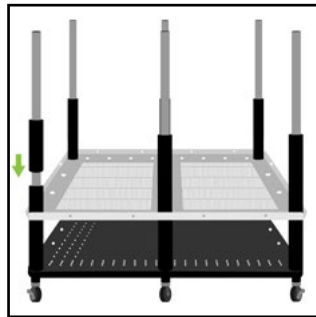

For **High-Profile** lighting racks, slip a 3.5" AND a 5.375" spacer onto each of the 6 poles to rest on the stainless steel shelf.

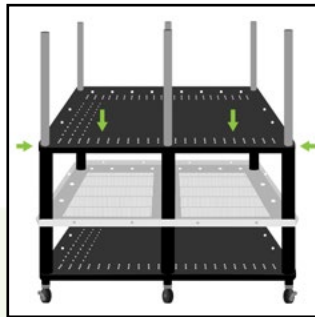

Slide a large rack shelf onto each of the 6 poles and rest it on the spacers. *(pictured - no heat cables)*

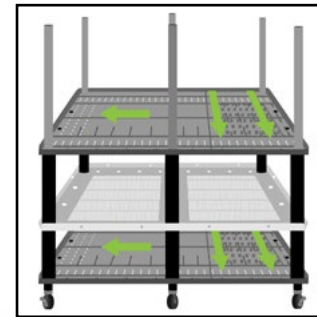

Ensure the runs match the shelf below. *(pictured - using heat cables)*

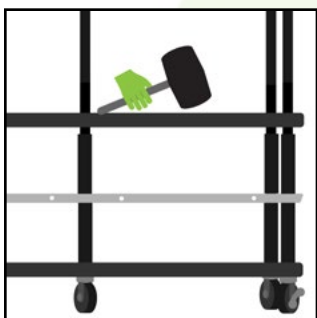

If you have trouble sliding the shelf onto the poles a **light** tap with a rubber mallet or your hands may be used.

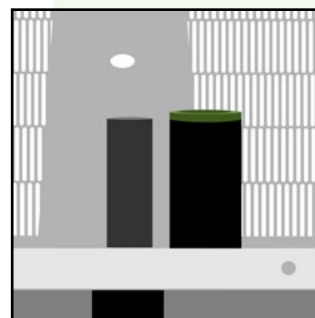

### Repeat Steps 2 & 3: UNTIL YOU REACH THE TOP OF YOUR SECTION

The section is complete when a spacer on top of the stainless steel shelf is taller than the remaining pole.



### If using multiple sections in your rack, proceed to Step 4: STACK DIFFERENT RACK SECTIONS TOGETHER



### If only one section is used in your rack skip to Step 5: TIGHTENING THE RACK TOGETHER

## Step 4: STACK DIFFERENT RACK SECTIONS TOGETHER

[Video](#) 7:49

Multiple sections of the same type or different types can be stacked on top of each other in the same rack.

### SAME SECTION TYPE



### DIFFERENT SECTION TYPE



Connect male pole connector ends to the top of each of the 6 poles.

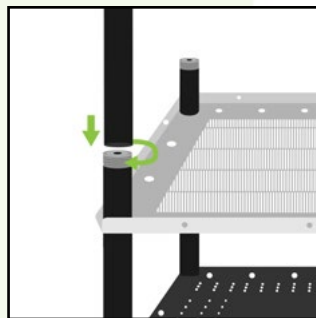

Screw 6 vertical poles on to each of the male pole connector ends.

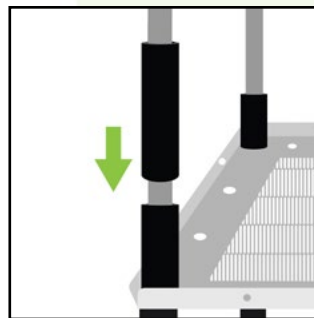

Slide spacers from previous rack section onto the poles



Place a new rack shelf on top of the spacers.

### Repeat Steps 2 & 4:

#### FOR AS MANY RACK SECTIONS AS YOU ORDERED

Use corresponding spacers depending on your tub height and lighting profiles for that section.

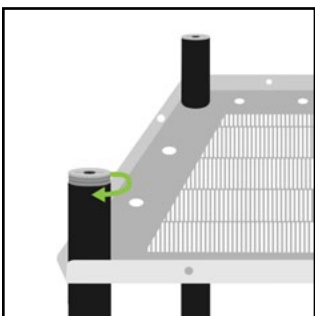

Once you reach the top of the last stack in your rack, attach a female connector end to each of the 6 poles.

## Step 5: TIGHTENING THE RACK TOGETHER

[Video](#) 9:02

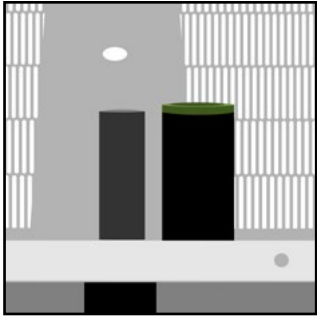

The rack is near completion when the spacers on top of the stainless steel tray are taller than the remaining pole length.

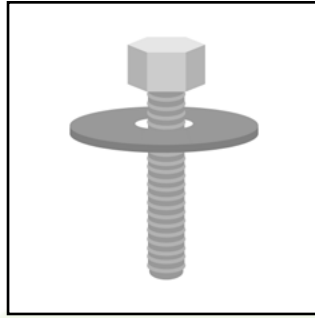

Place a rack tightening bolt through a rack tightening washer.

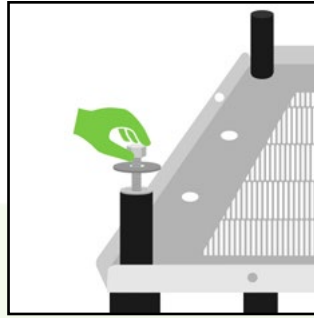

Align the bolt with the hole in the female pole end and hand tighten on all 6 poles.

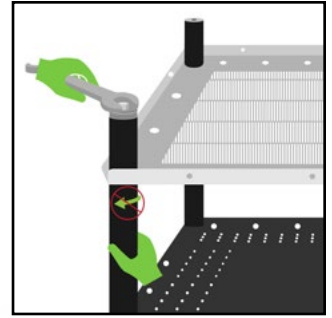

A wrench is not provided but can be used for additional tightening.

Tighten the bolts until the spacers on the shelf below are hard to turn.



Avoid over-tightening as it may damage the threading.

Move on to **Step 6** if you will be using optional accessories.

If not, fill your rack with Tubs.



## Step 6: ATTACHING OPTIONAL ACCESSORIES



Heating Cables



Tub Security Clips



10-Outlet Surge Protector



Surge Protector Mounting Bracket

## Step 6A: HEAT CABLES

[Video](#) 9:59

Vision Heat cables can attach to the runs of the large rack shelf with tubs resting above. *Please read this entire section before installing the heat cable(s).*

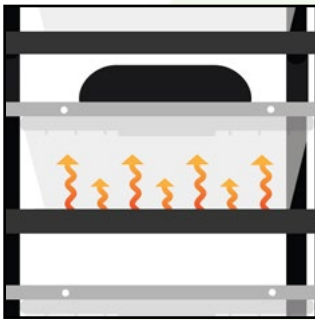

Depending on the animal in your rack, targeted underbelly heat may be required.



Vision Heat cables can attach to the runs of the large rack shelf with tubs resting above.

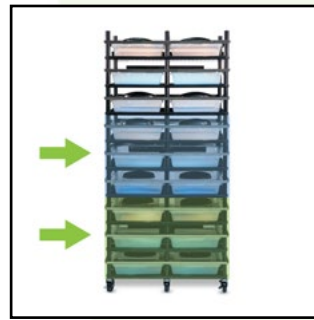

Two heat cable lengths are available depending on the size of your rack.

**26' Heat Cables** extend up to two sections.



**52' Heat Cables** extend up to three sections.

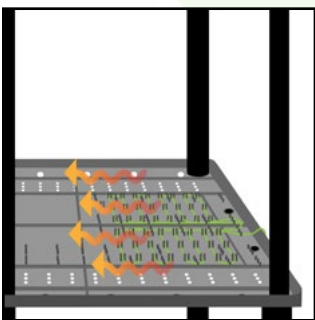

Heat cable should be attached to one end of the shelf to ensure a proper gradient of heat transfer in the tub.

The shelves are designed with two different sections of runs depending on the size of the tub used.

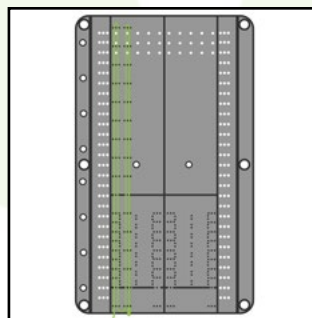

The longer narrower run section is used for smaller tubs V-15, V-18, V-35s & V-35.

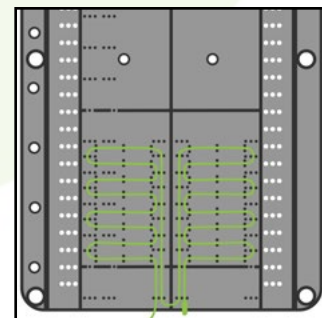

The shorter, wider section of runs is used for V-70 tubs.



Heat rises which allows for less heat cable at the top of the rack compared to the bottom.



Start on the upper most shelf in the rack and work your way down the rack with the heating cable(s).

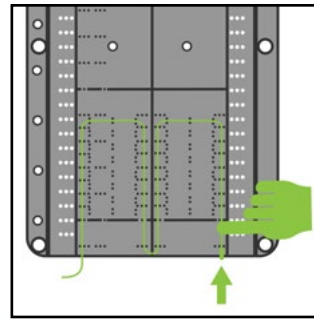

Start by using the end of the heat cable without the plug, and press the cable into place through the built in runs.

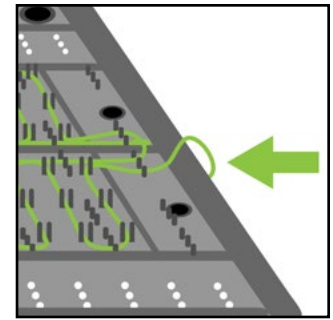

To prevent snags from a tub being placed in the rack, provide slack to the cable before proceeding to the next shelf.

The more cable used in a shelf the warmer the tub can get.

A thermostat/temperature regulator is required.

The diagrams below provide examples of heat cable showing cable routing options to provide less or more heat, depending on your individual needs.

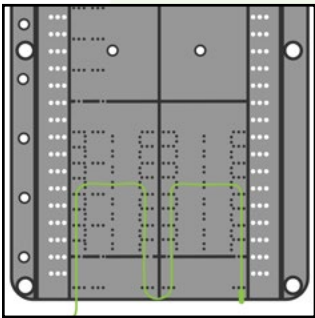

**V-70**  
Minimal Heat

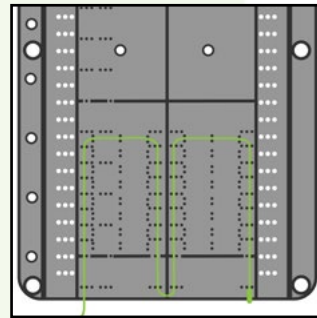

**V-70**  
Minimal Heat

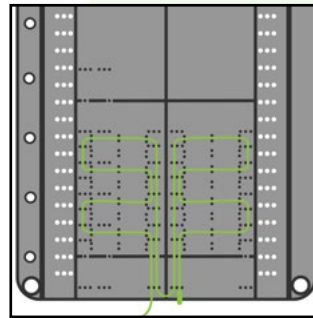

**V-70**  
Moderate Heat

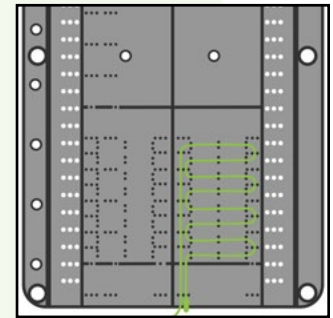

**V-70**  
High, Targeted Heat

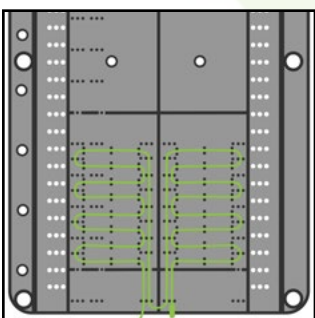

**V-70**  
High Heat

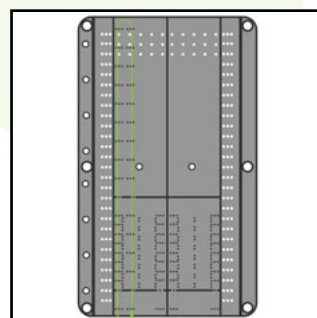

**V-15, V-18, V35s,  
V-35**  
Minimal Heat

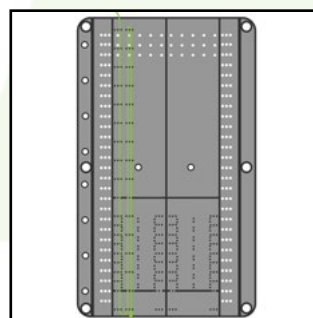

**V-15, V-18, V35s,  
V-35**  
Moderate Heat

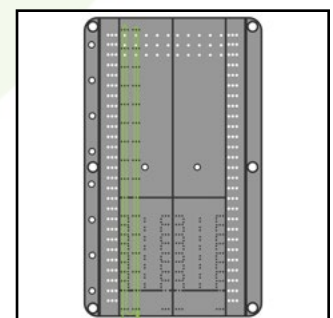

**V-15, V-18, V35s,  
V-35**  
High Heat

## Step 6B: SECURITY CLIPS

[Video](#) 11:34

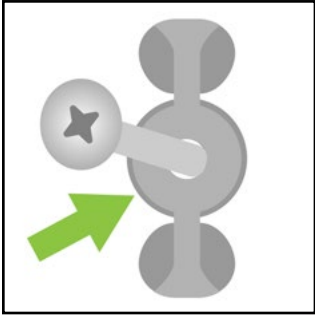

Place the small screw through the hole of the Security Clip.

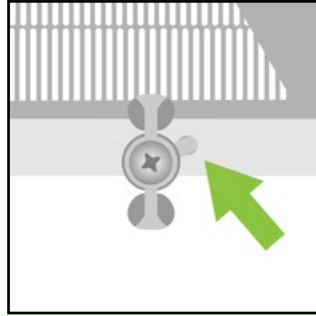

Place Security Clip into one of the holes on the front of the Stainless Steel Tray.

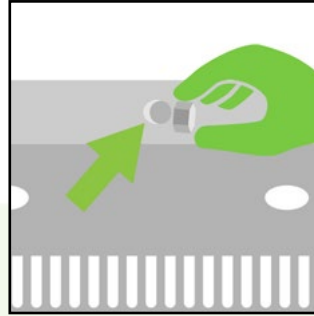

Screw the small nut onto the back end of the screw.

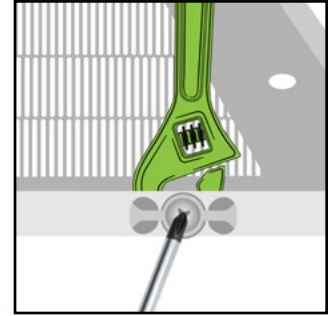

Tighten with a screwdriver and wrench or pliers. Tighten until the Security Clip is snug but easy to turn when needed.

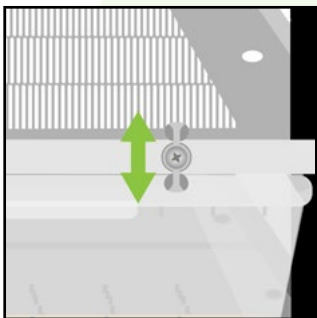

Slide the tub into place and turn Security Clip 90° to secure the tub.

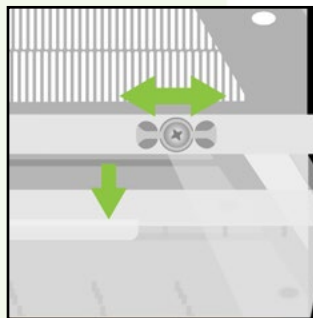

When removing the tub, turn the Security clip 90° either way, and slide the tub out of the rack.

## Step 6C: 10 OUTLET SURGE PROTECTOR AND MOUNTING BRACKET

[Video](#) 12:17

With the Versa-Rack accommodating various overhead lighting and heating options, power cord management is essential.

Our custom designed 10 outlet power strip and mounting bracket are the perfect solution.



### Attach the power strip to the bracket.

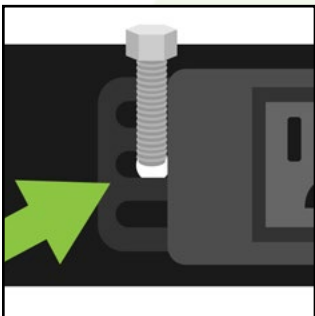

Slide the inner bolts of the bracket through the back of the power strip, into one of the holes on either side of the power strip.

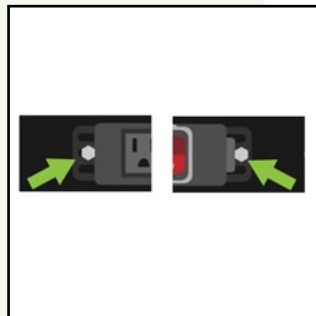

Ensure the bolts are in the same hole on each side to ensure the power strip is straight.

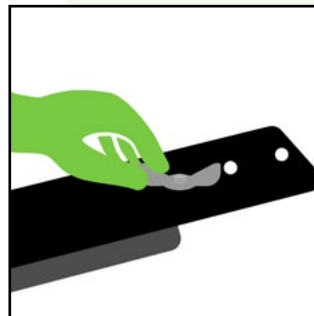

Tighten wing nuts onto each bolt.

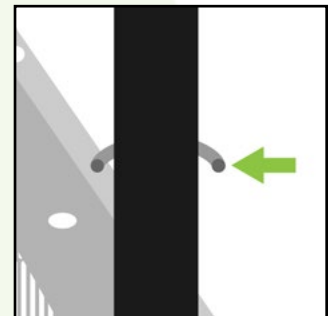

Place a U-shaped bolt around a pole on one side of the rack.

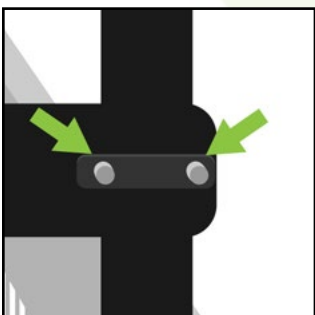

Slide the mounting bracket and V-bracket onto the U-shaped bolt.

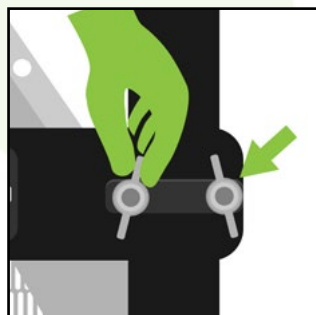

Finger tighten the wing nuts onto each side of the U-shaped bolt. Repeat on other side.

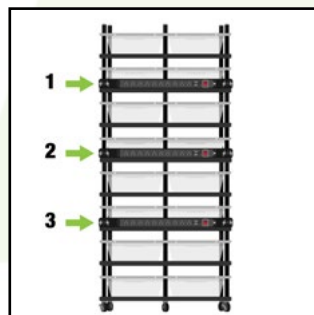

Repeat these steps depending on the number of brackets you plan to use in your rack.



Place the lighting for your rack. Your Vision Versa Rack is Complete.

Thank You For Choosing

